

EDITION 1-2013



WERKSTATT MAGAZIN



THE *triple* GERMAN CONNECTION



WELCOME TO WELZH WERKZEUG

THE *triple* GERMAN CONNECTION

We are one of the UK's Fastest Growing suppliers of workshop tools and equipment, In offering some of the most up to date products available, best value and a service that is second to none.

We hold extensive stock in both our U.K & European based warehouses to ensure prompt delivery and continuity of supply to our customers, All Welzh Werkzeug products are unconditionally guaranteed against faulty material or workmanship*

With over 4000 innovative products we thrive to have innovative & cost effective products for the modern day professional Mechanic all of our products are sourced and produced from quality manufacturers with similar high standards to our own - we are market leaders at introducing the very latest products to the automotive sector, ensuring our customers are the first to introduce them to their customers.

Further expansion of our Company has been the acquisition of exclusive partnerships with some of Germany's most famous tool brands.

BGS TECHNIC

Since the first production in 1970 the BGS brand stands for fine quality and enjoys a perfect reputation among its customers in Germany and Europe.

With a range of more than 3,000 products BGS ensures there is a tool for every type of job.

MULLER-WERKZEUG (Tool Innovator)

Located in Kueps, Germany - Müller has over a 30 year period built a well deserved reputation for providing innovative solutions in Automotive Tools.

Their direct and rapid information exchange between workshop, engineering and development ensures rapid implementation and problem-focused Tool solutions.

The Müller product range consists of some of the world's most Innovative Tools, with worldwide patents covering many of the products.

Keep up to date with our latest new items or complete range refer to our website www.welzhwerkzeug.com



BOSCH	DELPHI
DENSON	SIEMENS

1047-WW FSI / PD / COMMON RAIL INJECTOR PULLER & SERVICE TOOL KIT FOR VAG GROUP

- ▶ For assembling and removal of FSI injectors
- ▶ Suitable for VW, AUDI, SEAT, SKODA, with
- ▶ Direct injection engines and engines with pump-injector units
- ▶ Use as OEM tool kit T10133 + T10163

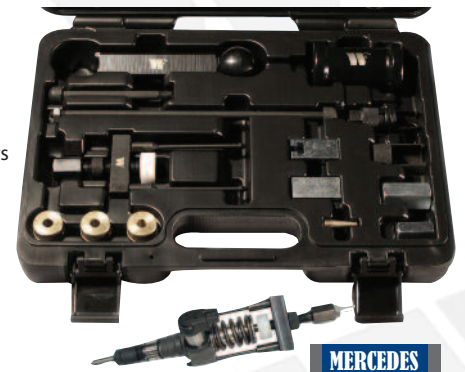

**MERCEDES
BENZ CDI**

67307-BGS 14PC DIESEL INJECTOR PULLER

- ▶ Suitable for the fast and safe removal of Bosch, Delphi, Denso and Siemens diesel injectors
- ▶ Ball joint allows hammer to be used in confined areas
- ▶ Set includes keys and deep open profile sockets, used to dismantle injectors, plus adaptors for attaching the slide hammer securely to the body of the injector



1014-WW INJECTOR SEAT CLEANERS

- ▶ Needed when changing or reconditioning diesel injectors
- ▶ Helps to avoid blow-back due to poorly seated injectors
- ▶ 19 mm hexagon pilot
- ▶ 15 x 19 mm reamer fits various makes and models
- ▶ 17 x 17 mm reamer fits BMW, Peugeot, Citroen, and Renault
- ▶ 17 x 19 mm reamer fits for Mercedes CDI
- ▶ 17 x 21 mm offset reamer fits for Fiat / Iveco



**5350-BGS
MERCEDES DIESEL INJECTION SOCKET**
Special socket for removing and mounting the Pressure valve holder on the diesel injection pump
Suitable for Mercedes-Benz models: 601, 602, 603, 605, 606, 615, 616 and 617

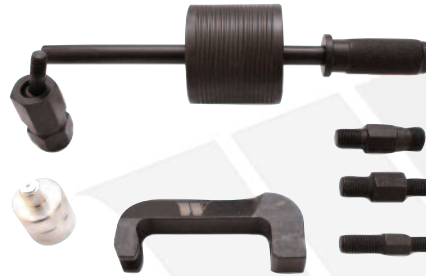

1030-WW 8 PIECE CDI INJECTOR PULLER SET

- ▶ With sliding hammer 1,70 kg
- ▶ Extra short: only 225 mm
- ▶ Especially for Mercedes-Benz CDI engines OM 611, 612, 613...
- ▶ Total length 350 mm
- ▶ 2 extract adapters M17X1,0 + M27X1,0



1116-WW HDI INJECTOR REMOVER

- ▶ Comprehensive set for removing Citroen / Peugeot 2.0/2.2HDi 16v fuel injectors
- ▶ Allows the removal of seized injectors without the need to remove the cylinder head
- ▶ Bridge fits perfectly on the cylinder head preventing damage to the area surrounding the injector



8309-BGS INJECTOR NOZZLE EXTRACTOR

- ▶ The 3-jaw puller allows a safe removal even of stuck injectors
- ▶ It is not necessary to drill a hole into the injector needle, thus even Injector needles which rotate when drilling a hole can be removed



8400-BGS MASTER DIESEL COMPRESSION TESTER KIT

- ▶ This comprehensive Diesel Engine Compression Tester kit covers a vast majority of modern engines fitted to most manufacturers' vehicles
- ▶ A large 2.5" diameter with 0-70 kg/cm2 or 0-1000 psi, coiled rubber hose with straight or optional right angled connection, plus a wide selection of glow plug and injector adaptors
- ▶ This set also includes claw, clamp and spacers for dummy profiling
- ▶ Use on Alfa, BMW, Chrysler, Daewoo, Fiat, Ford, Hyundai, Isuzu, Land Rover, Mazda, Mercedes, Mitsubishi, Nissan, Opel, PSA, Renault, Saab, Suzuki, Toyota, VAG, Vauxhall and Volvo
- ▶ Suitable for most cars, trucks, buses, agricultural and Marine engines



1069-WW
GLOW PLUG REMOVAL SET

- ▶ For removing damaged and broken glow plugs from cylinder heads
- ▶ Ideal for use where glow plug has sheared off just below the hex, or Flush with the cylinder head
- ▶ Removes 8mm and 10mm glow plugs
- ▶ Comprehensive kit complete with instruction manual

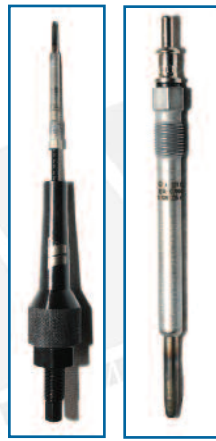

M8 M10



**98% DAMAGE
FREE REMOVAL**



1093-WW
VIBRATION GLOW PLUG REMOVER

- ▶ Allows loosening of stubborn glow plugs to minimize the risk of tear-off for the glow plugs
- ▶ Can also be used on screws where a low torque is required
- ▶ Supplied with 4 special impact glow plug sockets and universal joint
- ▶ 4-stage torque adjustable to approx. 20-30-40-50 NM



1018-WW
**TRANSMISSION OIL FILLER +
9PC ADAPTOR KIT**

- ▶ For filling gearboxes and differentials with oil
- ▶ With 8-pc adaptor set with different angles and thread types
- ▶ Ideal for filling Mercedes 722.9, VW / Audi DSG and CVT transmissions
- ▶ Hose length 160 cm
- ▶ Can be used up to SAE 140



9991-1-WW
SPARE TANK



1049-WW
NEW GENERATION OIL FILTER SET

- ▶ For oil filters and filter crankcase
- ▶ Assortment for removal and reassembly of the oil filter and changing the filter housing
- ▶ All filters are with 3 / 8" drive for Exact torque suit
- ▶ Universal use on VAG, Opel, Renault, Toyota, PSA, Renault, Mercedes, Volvo, Ford etc,
- ▶ Application Chart Included



997-BGS
OIL FILTER CAP WRENCH FOR HYUNDAI / KIA



998-BGS
OIL FILTER CUP WRENCH FOR TOYOTA

- ▶ Installed in Toyota Auris, Corolla, Premio and Prius

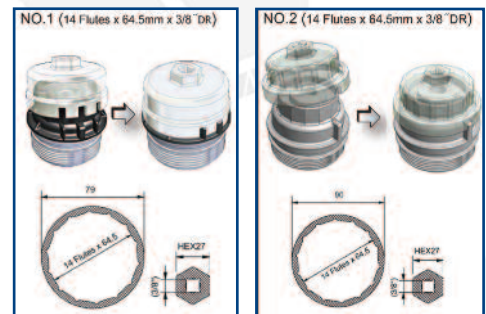
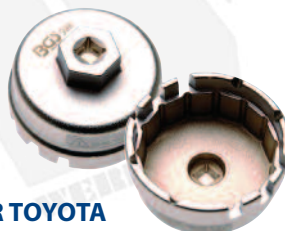



8315-BGS
PRESSURE BRAKE BLEEDER

- ▶ Air-assisted bleeding of brake and clutch systems
- ▶ Brake fluid and compressed air is separated by a diaphragm
- ▶ Filling hose has a quick coupling for easy adapter installation
- ▶ Connection hose also comes with a 5 litre brake fluid reservoir
- ▶ Comes with one adaptor E20 for most common brake systems

UNIVERSAL
ABS



67241-BGS
PROFESSIONAL BRAKE FLUID TESTER

- ▶ High accuracy and reliability
- ▶ Test results are displayed on 4 LEDs
- ▶ With protective cap to protect the sensors
- ▶ Works on a 1.5V AAA battery (included)
- ▶ Easy to use, switch on, insert sensors into the brake fluid

8316-BGS
MASTER ADAPTOR SET FOR AIR BRAKE BLEEDER

- ▶ With quick coupling, fits 8315-BGS Brake Bleeder
- ▶ Suitable for use with most pressure brake bleeders
- ▶ Includes adaptors for European, American and Japanese cars example, BMW/Audi Ford Nissan Toyota Etc.



2187-BGS
TRAILER SOCKET

- ▶ The tester allows a quick check of 12V electrical systems on trailers, cars, motorhomes, etc.
- ▶ Suitable for 7-pin connect



1034-1-WW
HYDRAULIC BRAKE FLARING TOOL

- ▶ For the use directly on car
- ▶ Use with steel pipes, copper, brass and aluminium pipes
- ▶ Also suitable for coated steel pipes.
- ▶ 4.75 mm (3 / 16"), 5,00 mm, 6,00 mm
- ▶ For double and convex flare to SAE and DIN
- ▶ Includes pipe cutter with deburring tool

BRASS
STEEL
ALU
COATED PIPES



8519-BGS
BRAKE BLEEDING BOTTLE

- ▶ 1L plastic bottle
- ▶ With holding chain and hook
- ▶ Variable length bleeding hose
- ▶ Bleeding nipple adaptor



3057-BGS
PROFESSIONAL BRAKE FLARING TOOL KIT

- ▶ For flaring of brake and hydraulic pipes
- ▶ Can be used on copper, brass, aluminium and steel pipes
- ▶ For inside and outside flaring
- ▶ For coated and non-coated pipes
- ▶ Incl. 4 pairs of jaws: 3/16" / 4.75 mm - 1/4" - 6 mm - 8 mm
- ▶ 5 mm jaws also available
- ▶ All parts available individually

VAG GROUP

62641-BGS (VAG 1.9 Ltr TDI)

62640-BGS (VAG 2.0 Ltr TDI)

3-PIECE CRANKSHAFT TIMING BELT PULLEY LOCKING TOOL KIT

► For VAG 1,9 and 2.0l TDI engines with round crankshaft wheel (use as OEM VAG T10050 OEM T10100)

► Includes: crankshaft locking tool, locking bolt for pump, locking plate for idler

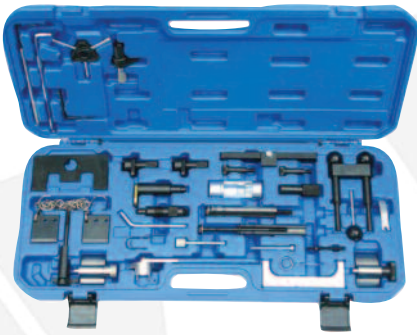
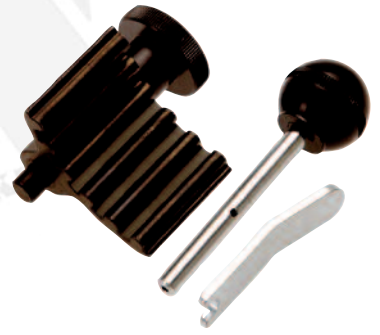

8155-BGS

MASER TIMING TOOL SET FOR VAG GROUP

► Contains important tools for adjustment: flywheel, crankshaft, camshaft fuel injection pump shaft, belt pulley, tensioning of the timing belt

► Complete classification chart included

► For 1.9/2.0 ltr. unit injector drive

► 1.9 ltr. TDI (normal diesel)

► 2.5 ltr. V6-TDI (no gasoline)

► 3.3 ltr. V8-TDI (no gasoline)

► 1.2 ltr. 3-cylinder and 1.4/1.6 ltr. gasoline engine



8565-BGS

CAMSHAFTS SOCKETS, VAG 1.8 / 2.8 TFSI

► Used for removal and installation of 4/3-way central valve on the camshaft adjustment

► Suitable for VW Passat, Audi A3, A4, A5, Q5 1.8l and 2.0 litre engines with chain drive

► To be used as OEM T10352 / T10352/1



1075-WW

VAG 2.0L FSI / TFSI KIT

► Fits for 2.0 L FSI and TFSI engines

► E.g. Golf, Touran, Audi A3, engines codes AWA, BMB, AXW

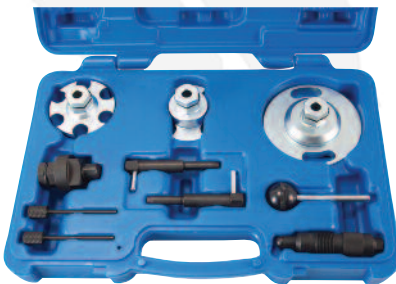

66205-BGS

2.7 / 3.0 TDI AND TDI CR (COMMON RAIL) CHAIN DRIVEN DIESEL ENGINE IN THE VAG GROUP

► Suitable for Audi A4, A5, A6, AB, Q5, Q7 and VW Touareg, Phaeton with engine codes: ASB, BKN, BKS, BMK, BMZ, BNG, BPP, BSG, BUG, BUN, CAMA, CAMB, CANA, CANB, CANC, CAND, CAPA, CARA, CARB, CASA, CASB, CASC, CATA, CCMA, CCWA, CCWB, CDYA, CDYB, CDYC, CEXA, CGKA, CGKB

► For locking the camshaft, crankshaft and

► Fixing the chain tensioner

► Required for timing chain replacement or engine repair



1072-WW

VAG FSI / TFSI KIT FOR 1.4 AND 1.6L

► Contains twin camshaft locking tools and a setting gauge holder

► Fits for engine codes AXU, BAG, BKG, BLF, BLN, BLP

► To check and adjust camshaft timing

► Required when replacing timing belts or timing chains



66210-BGS

ENGINE TIMING TOOL SET FOR VAG 2.4 & 3.2 FSI

► For checking and adjusting the engine timing

► Suitable for Audi V6, V8 and V10 engines with chain

► Includes: camshaft locking tool (use as OEM T40070), crankshaft locking pin (use as OEM T40069), chain tensioner locking pin (use as OEM T40071)

1076-WW

VAG TIMING TOOL SET FOR 1.6/2.0

► Common Rail Engines

► 10- piece engine locking tool kit for the 5th generation VAG "blue motion" engines fitted with a common rail diesel engine.

► Fits on: Audi A1, A3 (8P) A4 (B8) A5, A6 (C6, C7), TT (8J), Q3, Q5

Skoda Fabia, Roomster, Practice Octavia II, Suber II, Yeti,

Seat Ibiza (6J), Leon III, Exeo, Altea, Alhambra II

VW Golf V, VI & Plus, Passat, Polo V, Jetta V, & VI, Scirocco III, Beetle II, II Caddy, Passat B6, B7 & CC, Touran, Sharan II, T5, Amarok

► Includes important tools for checking and adjusting engine timing after e.g. timing belt replacement

► Crankshaft locking tool

► Camshaft locking tool

► Camshaft wheel puller

► Balance shaft fixing tool



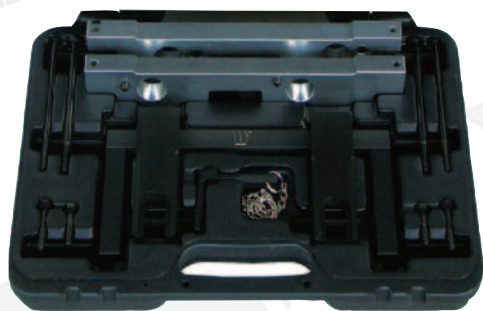

1127-WW
BMW ENGINE TIMING TOOL SET FOR N51, N52, N53, N54

► Contains important tools, e.g.: camshaft assembling / disassembling, timing belt change, checking and adjustment of valve timing, camshaft locking tool (to be used as OEM 114280)

- Transmitter wheel locking tool (to be used as OEM 114290)
- Crankshaft locking tool (to be used as OEM 110300)
- Suitable for following models: 128i, 130i, 135i - E81 / E82 / E87, 323i, 325i, 328i, 330i, 335i - E90 / E91 / E92 / E93, 523i, 525i, 528i, 530i - E60 / E61, 535i, 630i - E63 / E64 730i - E65 / E66 X3 2.5 / 3.0 - E83, X5 3.0 - E70 Z4 2.5 / 3.0 - E85 / E86



8534-BGS
TIMING TOOL KIT FOR BMW M52, M54, M60, M62

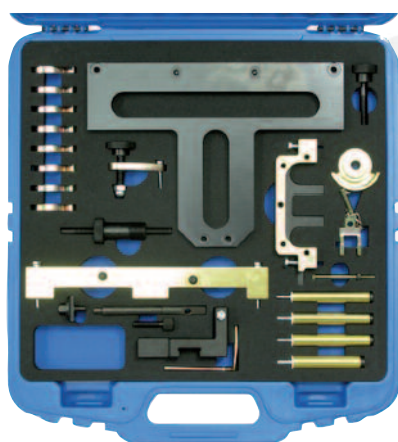

62617-BGS
BMW ENGINE TIMING TOOL SET FOR N42 N46

► For engine codes: N42, N46, B18/-A, B20/-A/-B

► Contains important tools, for: camshaft assembling / disassembling, valve timing of camshafts

► Fits followings models: BMW: 1, 3, 5, X3, Z4 (type series E87-46-60-85-83-90-91)

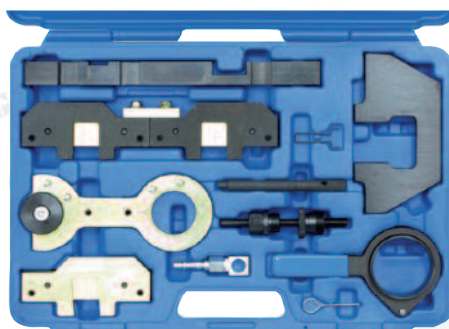

8573-BGS
FLYWHEEL LOCKING TOOL FOR BMW

► For locking the flywheel (crankshaft) when loosening the flywheel screws, loosening the crankshaft pulley screws or other jobs where a locking of the crankshaft is required

► Suitable for following BMW engines: M47T2 - M47TU - M57T2 - M57TU - M67 - N45 - N45T - N46 - N46T - N51 - N52 - N53 - N54 - W17

62615-BGS
ENGINE TIMING TOOL KIT FOR BMW ENGINES

► M40, M43, M42, M44, M50, M52, M 54, M56 (engines with double camshafts)

► Contains important tools for: camshaft assembling / disassembling, M 40 timing belt change, valve timing of camshafts

► Fits followings models: BMW: 3, 5, 7, X3, X5, Z3, Z4, type series E30-31-32-34-36-38-42-46-53-60-61-65-66-83-85)

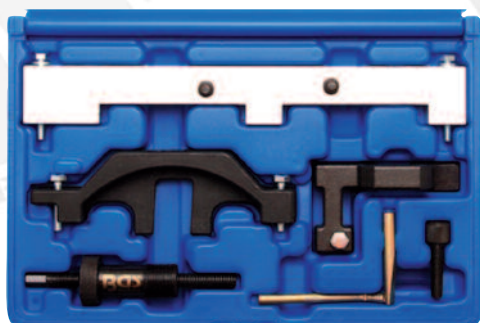

62614-BGS
TIMING TOOL SET FOR BMW 1.6L

► Suitable for timing chain driven petrol engines with Vanos, engine codes N40, N45, N45T (B16)

► For following BMW Models: 116 1.6 i E81/ E 87, 316 1.6 i E46 / E90, 316 1.6 Ci E46, 316 1.6 ti E46

► Includes following tools: timing chain tensioner tool, crankshaft timing pin, thread bolt, vanos timing ruler, inlet camshaft alignment tool, exhaust camshaft alignment tool

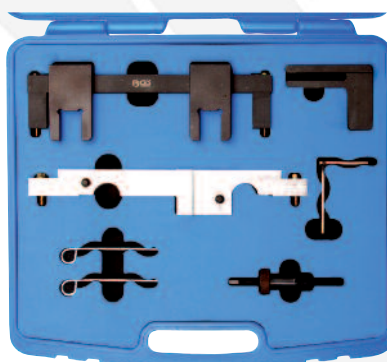

8570-BGS
ENGINE TIMING TOOL KIT FOR BMW 1/3/5 SERIES

► With chain driven engines

► Includes Vanos sensor alignment tool

► BMW 1 series E81/82/87/88, 3 series E90/91/92/93 and 5 series E60/E61

► Engine Codes: N43 B16A/AA, N43 B20A/AA and N43 B20AY 2006 onwards

FRENCH CONNECTION RENAULT, PSA



1024-WW TIMING TOOL KIT FOR DCI ENGINES

- ▶ For Renault, Opel, Nissan common rail engines (1,5 - 1,9 - 2,2 - 2,5 ltr.)
- ▶ Contains many tools needed for positioning and locking the crankshaft and camshaft when repairing the timing belt and engine
- ▶ For Renault Avantime, Clio, Espace, Kangoo, Laguna, Master, Megane, Modus, Scenic, Twingo, Trafic
- ▶ For Opel Movano, Vivaro
- ▶ For Nissan Almera, Interstar, Kubistar, Primastar, Note, Micra, Primera, Qashqai

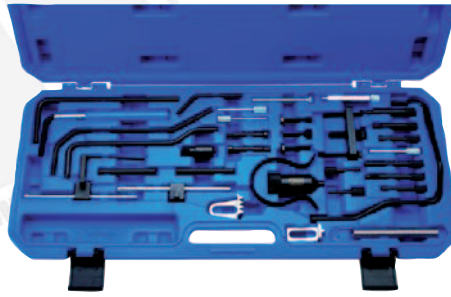

8152-WW MASTER TIMING TOOL SET FOR CITROEN / PEUGEOT

- ▶ Contains important tools for adjustment of: flywheel, crankshaft, camshaft, fuel injection pump shaft, belt pulley, tensioning of the timing belt

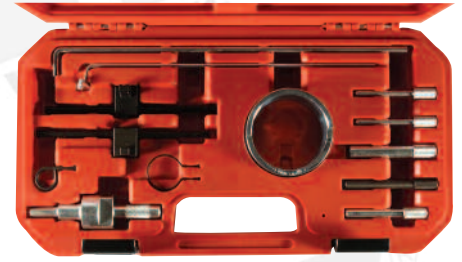

1071-WW TIMING TOOL SET FOR EW CODED PSA ENGINES

- ▶ Used on Citroën / Peugeot
- ▶ Models, Xsara/Picasso/C5/C4/Evasion/Synergie/C8/jumpy/Dispatch and Peugeot 206/307/406 Coupe/607/806/807/Expert
- ▶ Engine Codes EW12j4(3FC) | EW10D-HPI(RLZ) | EW10j4S(RFK) | EW10j4(RFN/RFR) | EW7j4(6FZ).
- ▶ EW is the prefix used on the vehicles engine number.
- ▶ A 3 digit code in the chassis number identifies the engine used in the vehicle

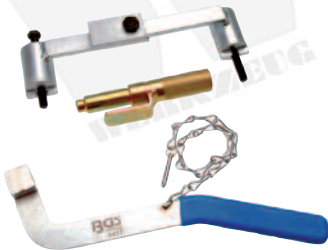

8417-BGS TIMING TOOL KIT FOR RENAULT / VOLVO 16V & 20V PETROL ENGINES

- ▶ With engine codes: B4164 S/S2, B4184 S/S2/S3/S9/S10, B4194 T/T2, B4204 S/S2/T/T2/T3/T5, B5202 FS, B5204 FT/T2/T3/T4/T5, B5234 T3/T4/T5/T6/T7/T8/T9, B5244 S/S2/SG/SG2/T3/T4/T5/T7, B5252 FS, B5254 T/T2/T4



8421-WW TIMING TOOL KIT FOR RENAULT / OPEL / NISSAN 2.0DCI CHAIN DRIVEN DIESEL ENGINES

- ▶ Includes important tools for adjusting the engine timing
- ▶ Suitable for following models:
Nissan: Primaster (08-09), Qashqai (08-09), X-Trail (07-08) with engine codes: M9R 780, 830, 832, 833
Renault: Koleos (08-09), Laguna (05-08), Mengane (07-08), Scenic (08-09) Trafic (07-08), Vel Satis (08-09)
engine codes: M9R 700, 721, 724, 740, 742, 446, 760, 761, 780, 802, 803, 805, 830, 832, 833
Vauxhall/Opel: Vivaro (07-08) engine codes: M9R 780, 782, 784

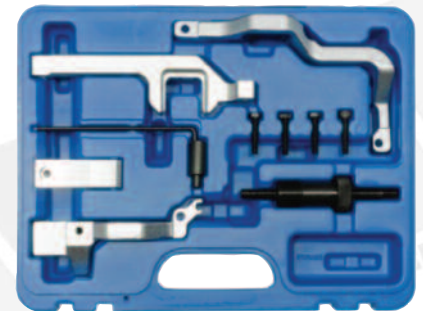

8302-BGS PSA 1.4/1.6 N12/N14 TIMING KIT

- ▶ 1.4VTi Valvetronic EP3 (8FS)
- ▶ 1.6VTi Valvetronic EP6 (5FW)
- ▶ 1.6THP Direct Injection EP6DT (5FX)
- ▶ 1.6THP Direct Injection EP6DTS (5FY) (chain driven petrol engines)
- ▶ Citroen C4 - C4 Picasso
- ▶ Peugeot 207 - 207CC - 308
- ▶ BMW Mini One - Cooper / Cooper S
- ▶ N12 1.4 & 1.6 Valvetronic & N14 1.6 Direct Injection



8154-BGS MASTER TIMING TOOL KIT FOR RENAULT

- ▶ contains important tools for adjustment of flywheel, crankshaft, camshaft / pumpshaft, fuel injection pump shaft, belt pulley, tensioning of the timing belt, includes adjusting gauge for camshaft, crankshaft, pumpshaft
- ▶ complete classification chart included
- ▶ for i.e. 1.4 ltr. + 1.6 ltr. + 1.8 ltr. + 2.0 ltr. each with 16 valves
- ▶ 2.5 ltr. 20V with double camshaft
- ▶ 1.2 ltr. + 1.4 ltr. + 1.6 ltr. + 1.7 ltr. + 1.8 ltr. + 2.0 ltr. + 2.2 ltr.
- ▶ diesel engines 1.9 ltr. + 2.5 ltr. + 2.8 ltr. (partly identical with Opel Arena/Movano and Volvo V/S 40)



8562-BGS VOLVO 4-, 5-, 6-CYLINDER TIMING KIT

VAUXHALL, OPEL



1073-WW

MASTER FIAT/ALFA TIMING KIT

- ▶ Contains important tools for adjustment: flywheel, crankshaft, camshaft, fuel injection pump shaft, belt pulley, tensioning of the timing belt
- ▶ To be used as OEM

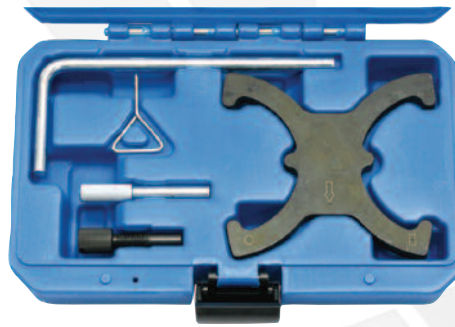

8218-BGS

FORD FOCUS 1.6 TI-VCT KIT

- ▶ 1.6 Ti HXDA Duratec DOHC petrol engine with variable
- ▶ Camshaft timing on both inlet and exhaust
- ▶ Use as OEM 303-735 303-748 303-1059 303-1097

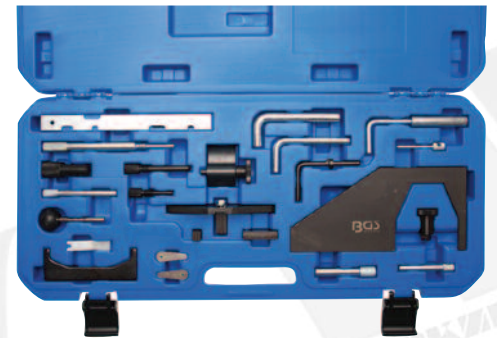

8156-BGS

MASTER TIMING KIT FOR FORD

- ▶ Petrol : 1.25 1.4 1.6 1.7 1.8 2.0 Zetec DOHC
- ▶ Diesel : 1.4 & 1.6 TDCi / 1.8 D / TD / TDCi / Di
- ▶ 1.9 D / 2.0 TDCi / 2.4D / 2.5 Di / Turbo
- ▶ Fiesta Focus / Puma Mondeo Galaxy / Courier Transit

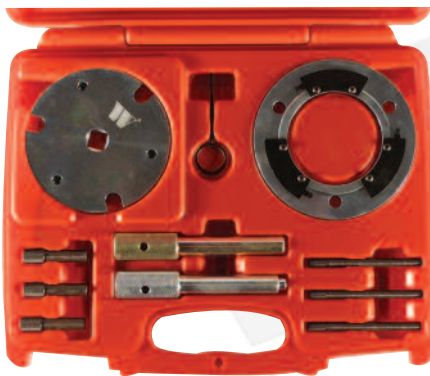

1088-WW

LOCKING TOOL SET FORD 2.0 / 2.4 TDCI

- ▶ Suitable for Ford 2.0 + 2.4 16V TDCi and TDDi engines, installed on Mondeo, Transit ('01-'04), etc.
- ▶ For engine codes FMBA / B, D5BA, ABFA, D3FA, F3FA, D2FA, D4FA, F4FA
- ▶ For locking or positioning of the cam, injection pump and crankshaft
- ▶ Needed for chain changes, engine repairs and work on the injection pump



8222-BGS

MERCEDES / CHRYSLER / JEEP TIMING KIT

- ▶ Chain driven petrol and diesel engines
- ▶ Mercedes Petrol C class, E class, SLK 1.8 2.0 2.3 / CDi 2.0 2.2 2.7 3.3 4.0 D / DT diesel 2.0 2.2 2.7 3.3 4.0 2.2 2.7
- ▶ CRD diesel - PT Cruiser 2.2 CRD / Jeep - Grand Cherokee 2.7 CRD



8500-BGS

CHRYSLER 2.5 CRD TIMING KIT

- ▶ Chrysler DOHC common rail diesel engines (belt) :
- ▶ Voyager / Grand Voyager R2516C R2516C5.05A- 01-2008
- ▶ Jeep Cherokee R2516L R2816K 01-2008
- ▶ LDV Maxus Van R2516L VM39/40B - 05-2009



8303-BGS

OPEL / VAUXHALL 3-CYLINDER KIT

- ▶ for engine codes: X10XE and X12XE
- ▶ includes important tools for e.g. changing the timing chain and other jobs on the valve train, working on the intake and exhaust camshafts, fixing the crankshaft
- ▶ suitable for following car models: Agila, Corsa 1.0 12V and 1.2 16V

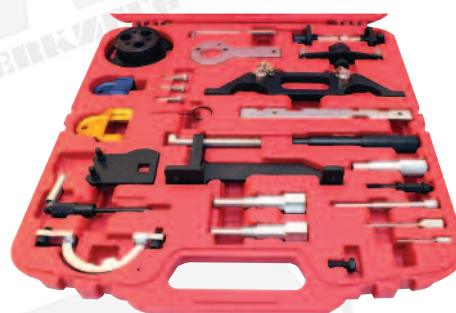

1074-WW

MASTER OPEL/VAUXHALL TIMINGTOOL KIT

- ▶ Contains important tools for: locking the camshaft and crankshaft, assembly and removal of fuel injection pump and water pump, tensioning and changing of the timing belt, belt pulley and flywheel
- ▶ Complete classification chart included
- ▶ Suitable for:
 - Opel Z 19 DT / Z 19 DTH engine (OHC and DOHC) e.g. in Vectra C and Signum '04
 - Opel Z13 DT engines e.g. in Corsa and Combo '04
 - Opel with Z 22 SE engine in Astra G, Vectra C, Zafira, Signum and Speedster Vx220 since '00 - '04
 - Opel with 1.0l - 12V, 1.2l and 1.4l 16V petrol engines (X10XE, Z10XE, Z10XEP, X12XE, Z12XE, Z14XEP) e.g. Corsa, Agila, Astra and Meriva
 - Opel 2.0l and 2.2l Ecotec diesel-engines (X20DTL, X20DTH, X22DTH) e.g. Astra, Astra, Caravan, Zafira, Vectra, Omega, Sintra and Frontera



- BEARINGS
- RUBBERS
- ROTARY SHAFT SEALS
- SILENT BEARINGS

1027-WW
UNIVERSAL BUSH / BEARING REMOVAL INSERTION KIT

- ▶ Universal type for all Car - LCV - HGV Models
- ▶ Also for assembly or disassembly of silent bearings, rubber- and ball bearings
- ▶ Also suitable for rubber bushes and rotary shaft seals
- ▶ Smooth running because of high-quality ball bearing on spindle screw nut



- 1037-WW**
UNIVERSAL G FRAME
- ▶ Complimentary tool for 1027-WW
 - ▶ Ideal for restricted access areas
 - ▶ Can also be used with Hydraulic spindle 7774X1
 - ▶ Impact wrench safe



1097-WW
RENAULT LAGUNA II BUSH TOOL

- ▶ For the removal and refitting of the rear axle bushes on Renault Laguna II.

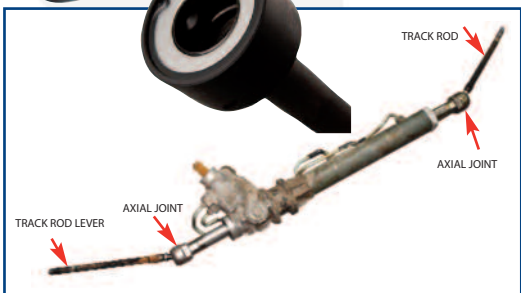

1003-WW (34-45 mm)
66527-BGS (45-50 mm)
AXLE JOINT REMOVAL / INSTALLER TOOL

- ▶ For fast and professional changing of the axle joints of cars and light commercial vehicles
- ▶ Automatic clamping of the joint heads
- ▶ Easy assembly of long tie rods because of open construction
- ▶ Saves up to 3 hours of working time

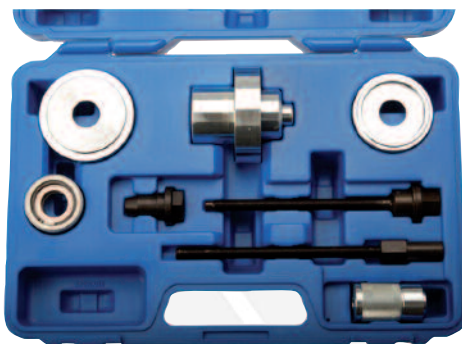

8253-WW
VW POLO 9N BUSH TOOL

- ▶ Designed for the plastic bearing bushes in the rear bush on the front control arm
- ▶ Fits Vw Polo, Audi A2, Skoda Fabia, Seat Cordoba, Seat Altea
- ▶ Quick assembly / disassembly on the vehicle



REMOVAL



INSTALL

66530-BGS
3-PIECE TOOL KIT FOR AXLE JOINTS

- ▶ 3 exchangeable clamping heads for a wide application area
- ▶ Sizes: 30 - 35 mm, 35 - 40 mm, 40 - 45 mm

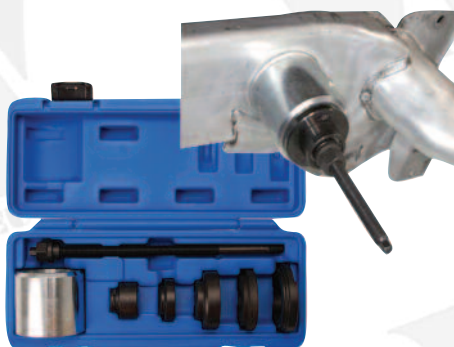

6456-BGS
8-PIECE SILENT BLOCK PULLER SET FOR BMW E38, E39

- ▶ For differential suspension bushes at rear axle
- ▶ Includes various press pieces, spindle and sleeve

GEN2 WHEEL-HUB BEARING KITS



VAG
FORD
VOLVO



1033-1-WW 1033-WW (EXCLUDING 78MM) MASTER GEN2 COMPACT WHEEL BEARING KIT

- ▶ For installing the compact wheel bearing
- ▶ GEN2 Type combined wheel hub and bearing unit
- ▶ Allows the most efficient and safe use
- ▶ Based on use with workshop press or on car solution
- ▶ Compatible For:
62 MM Audi A2 VW Lupo
66 MM Audi A2, Vw Polo, Vw Fox, Skoda Fabia, Seat Ibiza
72 MM Vw Polo, Skoda Fabia
78 MM Ford Focus II, C-Max Mazda 3, Volvo C30, C70, S40, V50

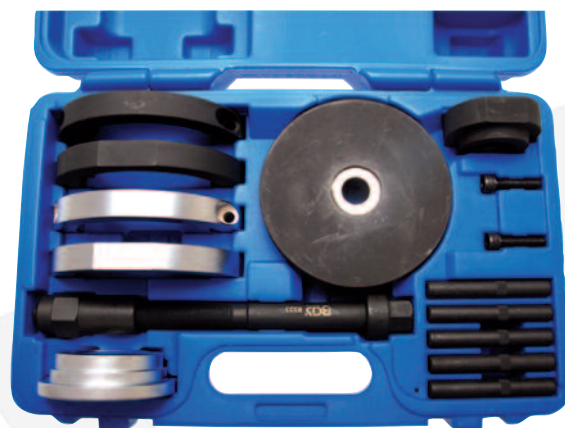

8324-BGS T5 GEN2 COMPACT WHEEL BEARING KIT

T5
TRANSPORTER
85MM

- ▶ Facilitates assembly and disassembly of wheel hub-bearing unit
- ▶ Suitable for VW T5 and Touareg with 16" rims

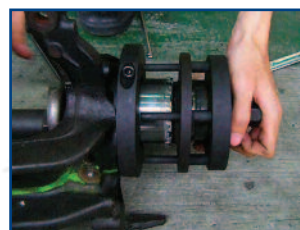

REMOVAL



INSTALL



1012-WW FRONT AXLE BALL JOINT EXTRACTOR VOLKSWAGEN T4 2.5 | 2.0

- ▶ Installer can be used insitu, saving valuable time and money
- ▶ The upper ball joint may be removed / installed in about 30 mins in using this tool without needing to remove the wishbone



1058-WW UNIVERSAL BEARING RING PULLER

- ▶ Universal bearing ring puller with a revolutionary crippling system
- ▶ Three legged with ultra sharp edges provides equal gripping
- ▶ Avoiding any slipping and tilt
- ▶ Fits all kinds of bearings and sleeves between 40mm and 60mm
- ▶ Exclusive
- ▶ Spare Legs Art: 1058-1

NO GRINDING

NO CHISELING

NO COMPARISON



419-BGS
3-PIECE DOUBLE JOINT
PLIERS SET, 300 MM

- ▶ Perfect for working in narrow places
- ▶ 1 straight long nose pliers
- ▶ 1 offset long nose pliers (45°)
- ▶ 1 flat nose pliers



8600-BGS
PROFESSIONAL HOSE CLIP PLIER

- ▶ Specially designed for removal and replacement of space-saving hose clips
- ▶ Hose-Clip-Locking-Function

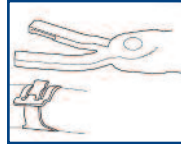

1051-WW
C.V JOINT PLIER

- ▶ For stainless steel hose clamps with a torque specification
- ▶ Specially designed for Ford, Opel, etc. VAG

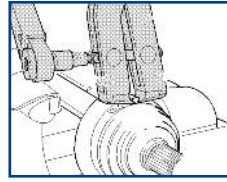

500015-MW
HOSSE CLAMP COMPRESSOR

- ▶ Compact design allows use in confined areas universal use



1117-WW
CLIC & CLIC-R FLEXI HOSE CLIP PLIER

- ▶ Turnable gripping piece guarantees universal use



1123-WW
8PC (16 FUNCTION)
COMPOSITE REMOVAL SET

467-BGS
RADIATOR HOSE CLAMP PLIER

- ▶ Universal for installation and removal of radiator hose clamps
- ▶ Allows use even in narrow spaces (due to the bowden cable)
- ▶ Bowden cable available as spare part Art.47
- ▶ Length 630 mm



1057-WW
NEW STYLE HOSE CLAMP PLIER FOR VAG

- ▶ Also usable on old style clips
- ▶ With Bowden cable 630mm long
- ▶ Special clamps for difficult to reach areas
- ▶ Ratchet lever with functional opening
- ▶ For use on e.g. cooling system pipes etc.



608950-MW
EXCENTRIC TURN KNUCKLE

- ▶ Multi-Purpose Inner Tie Rod End Remover Installer Tool
- ▶ Special Patent opening Design allows for the tool to be used in situ
- ▶ The master tie rod tools easily replaces inner tie rod ends without removing the rack & pinion



1048-WW (57mm - 120mm)
1099-WW (80mm - 190mm)
FLEXI JAW OIL AND FILTER PLIER

- ▶ Jaws can be inclined up to 90° in both directions
- ▶ For easy removal of oil and fuel filters
- ▶ Ideal for loosening filters in hard-to-reach areas
- ▶ Jaws adjust in 4 positions every 45°





5186-WW
**96-PIECE TORX, SPLINE,
 ALLAN KEY SET**

TORXS
SPLINES
HEX KEYS

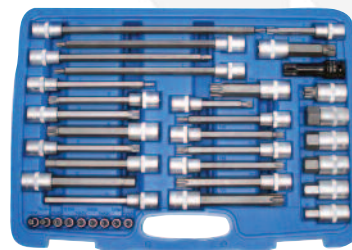

5184-BGS
38-PIECE CAR ASSEMBLY BIT SOCKET SET

- ▶ ¼, 3/8, 1/2 dr
- ▶ Unique assortment for a great number of specific operations in motorcar assembly

1085-WW
**ANTI SKID
 SOCKETS 3/8DR**

- ▶ Allows for the removal of rounded bolts
- ▶ Ensures Grip were other sockets fail
- ▶ Molybdenum steel ensures repeated use
- ▶ Sizes: M8- M19



1083-WW (IMPACT)
1084-WW
6-PIECE IMPACT ADAPTOR SET

- Content:
- ▶ 1/4" int. X 3/8" ext.
 - ▶ 1/2" int. X 3/4" ext.
 - ▶ 3/8" int. X 1/4" ext.
 - ▶ 3/4" int. X 1/2" ext.
 - ▶ 1/2" int. X 3/8" ext.
 - ▶ 1/2" int. X 3/4" ext.
 - ▶ 3/4" int. X 1/2" ext.



1106-WW
LONG ANTI SKID SOCKETS 1/4DR

- ▶ Special Left Drill Socket
- ▶ Perfect for removing broken glowplugs etc
- ▶ Sizes: 2.6 MM, 3.2 MM, 3.5 MM, 4.5 MM, 6.5 MM, 8.25 MM

800100-MW
**ALLOY WHEEL IMPACT
 SOCKETS**

- ▶ Suitable for both, manual and air impact wrenches
- ▶ With plastic cover for perfect protection of aluminium rims
- ▶ With ball retaining groove and hole
- ▶ Length 85 mm



17,19,21



5484-BGS
26-PIECE IMPACT BIT SOCKET SET

- ▶ T25-T30-T40-T45-T50-T55-T60-T70-T80
- ▶ 5-6-8-10-12-14-17-19 mm
- ▶ M5-M6-M8-M9-M10-M12-M14-M16-M18

IMPACT PROOF

SPLINES

TORXS

HEX KEYS



10-32 MM

**5207-BGS 14-PIECE
 ½" DEEP IMPACT
 SOCKET SET**

- ▶ Pro torque finish
- ▶ 10-12-13-14-15-17-18-19-21-22-24-27-30-32 mm

1108-WW
8 TON HYDRAULIC BALL JOINT SEPARATOR



WATCH THE VIDEO AT
www.welzhwerkzeug.com



1834-WW
MASTER BALL JOINT SERVICE KIT

- ▶ A universal set of tools for the Removal & Installation of press-fit parts
- ▶ E.g. Ball joints, Universal joints and light truck brake anchor pins

LGV
SUV
MPV



22



28



34

1020-WW
THREE PIECE BALL JOINT SEPARATORS

- ▶ Suitable for use in confined spaces and on a number of makes of vehicles including, Audi, BMW, Ford, Chrysler, Opel, Saab, Volvo, Volkswagen, Nissan, Toyota
- ▶ Sizes included 23mmx55mm, 28mmx55mm, 34mmx63mm



1790-BGS
HEAVY DUTY BALL JOINT SEPARATOR KIT 6-PIECE

- ▶ For removing ball joints, steering knuckles, Tie rod ends
- ▶ Especially suitable for vans, four-wheel vehicles and LGVS
- ▶ Universally usable by 5 quick Changeable-forks
- ▶ Clamping and adjustable pressure range

- 1x quick release fork, 20 mm opening
- 1x quick release fork, 22 mm opening
- 1x quick release fork, 24 mm opening
- 1x quick release fork, 27 mm opening
- 1x quick release fork, 30 mm opening

1032-WW
WISH BONE LEVER SUPPORT BAR

- ▶ Easy removal of fork legs
- ▶ Helps in removing particular ball joints
- ▶ Much safer technique than using traditional tools
- ▶ Movable hook in control arm
- ▶ Adjust to fit 98% of all cars





25105-BGS (1/4DR)
25106-BGS (3/8DR)
25107-BGS (1/2DR)

EXTENDABLE FLEXI HEAD RATCHETS

- ▶ 3 position adjustable and lockable
- ▶ Ratchet head can be angled in 10 positions
- ▶ 72 fine tooth



TWISTY

105-BGS (1/4DR)
106-BGS (1/8DR)
107-BGS (1/2DR)

- ▶ Simply turn the handle to use the ratchet
- ▶ Minimising the space needed for working

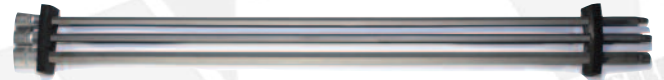

1064-WW
SPECIAL EXTRA LONG SPLINES FOR DRIVE SHAFTS

- ▶ Allows for the quick demounting / mounting of the axle shaft
- ▶ Ideal for VAG Group

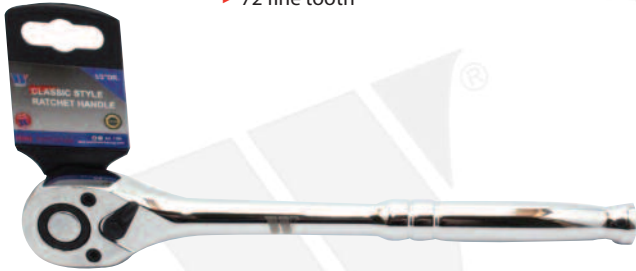

1102-WW (1/4DR)
1103-WW (3/8DR)
1104-WW (1/2DR)

CLASSIC HAND RATCHET SERIES

1021-WW
MULTI LOCK AVIATION SPANNERS

- ▶ Allows use in areas restricted with conventional wrenches
- ▶ New multilock head profile allows use on 7 head variations



1001-WW
4 PIECE EXTRA LONG FLEXI HEAD E-PROFILE RATCHET SPANNERS



1082-WW
EXTENDABLE FLEXI HEAD PRY BAR

1090-WW
7-PC RATCHET SPANNER SET



1091-WW
8PC FLEXI HEAD RATCHET SPANNERS

- ▶ 8-19mm
- ▶ 72 Fine Toothed



5° space requirement for each turn





1098-WW

OXYGEN SENSOR THREAD REPAIR KIT

- ▶ Allows the user to repair damaged Lambda (Oxygen) sensor threads with ease
- ▶ Complete with different adaptors to suit varying threads
- ▶ Includes 2 x taps M18 x 1.5mm x 50mm and M20 x 1.5mm x 50mm
- ▶ Kit Includes reamer and insertion tools
- ▶ Spares available Art: 66215-1



1125-WW

RATCHETING TUBE CUTTER FOR EXHAUST PIPES

- ▶ Fits pipes between 28-67 MM
- ▶ Cutting depth 6 MM
- ▶ Spare blade (66255)



STEEL

COPPER

STAINLESS

WALL CONDUIT



1060-WW 12 PT

1100-WW E-PROFILE

POLY V BELT SPANNERS

- ▶ To operate the automatic tensioning device of the belt pulley
- ▶ Through the narrow and long design is one possible to use even in confined spaces
- ▶ Suitable for e.g. all European cars
- ▶ Length: 460 mm
- ▶ AVAILABLE IN THE FOLLOWING SIZES: 1, 3, 15, 16, 17, 19mm
- ▶ E10-E12-E14-E16-E18

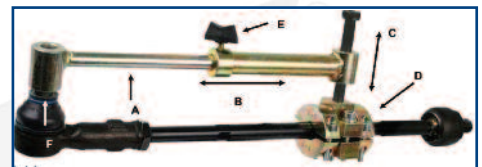

8305-BGS

TRACK ROD REMOVAL / SETTING KIT

- ▶ Allows the replacement of the track rod ends without any additional alignment
- ▶ The track rod is clamped onto the axial tie rod and measure the ball pins dimensions at the end of the tie rod
- ▶ Almost totally universal due to the various clamping and fixing connections supplied
- ▶ Cuts down the working time and cost needed when this set is not used

- 1061-WW (COMPLETE KIT)
- 1017-WW (HYDRAULIC RAM & WHEEL HUB UNIT)
- 7772 (HEAVY DUTY SLIDE HAMMER & WHEEL HUB UNIT)
- 7774-X (HYDRAULIC RAM)

UNIVERSAL HYDRAULIC DRIVE SHAFT / HUB PULLER KIT

- ▶ Simplifies the removal of the wheel hub and release of the drive shaft
- ▶ Suitable for almost all 3, 4, 5 and 6 holed hubs
- ▶ Hydraulic Spindle pressure 12 – 15 Ton Max
- ▶ Ideal use for e.g. VAG Group, Audi, Opel, Citroen, Renault, Ford, Volvo etc

HYDRAULIC

UNIVERSAL

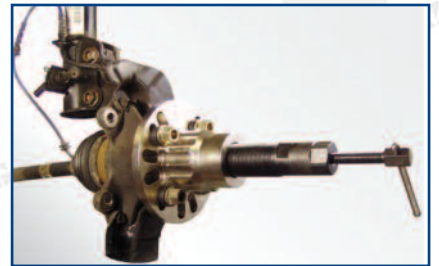
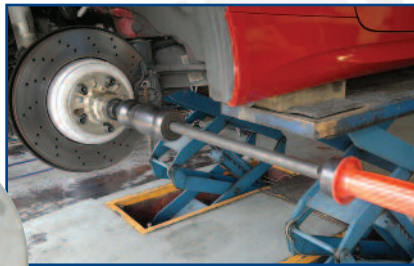

1005-WW
18-PIECE RADIATOR COOLING SYSTEM TESTER KIT

- ▶ For the testing of automotive pressurized cooling systems
- ▶ Finds cooling system external leaks and detect internal leaks
- ▶ Caused by a blown head gasket, or a cracked block or head
- ▶ Universal use for all European, USA, Asian Vehicles
- ▶ All adaptors available individually

8514-BGS 9-PIECE TRUCK COOLING SYSTEM TESTER KIT

- For use on the following LGV,
- ▶ DAF-XF 95, XF 105
 - ▶ Scania-113, -114, -124 and -125
 - ▶ Volvo-FH 12
 - ▶ Iveco-Daily 2000 C-Series, Renault-Magnum
 - ▶ MAN-L 2000, -TGA
 - ▶ MB-Actors, -Atego, Axor, -ECO 8401, 1728, MAN- F 90, -F 2000, Iveco-EURO-Star, -EURO-Tech, Euro-Truck, Strahlis
 - ▶ MB-Sprinter <2006), -Vito



1126-WW
19PC TERMINAL TEST KIT WITH DUAL LEAD INDICATOR

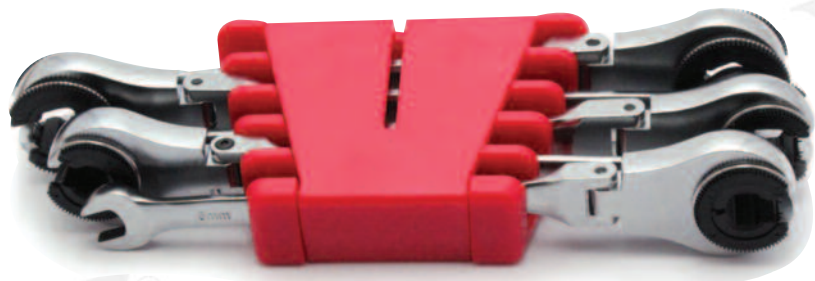

1096-WW
RATCHETING BRAKE PIPE SPANNERS SET

- ▶ Ideal for use on brake pipes
- ▶ Unique Concept flare nut ratcheting action
- ▶ Flexi-head allow use in confined areas
- ▶ Sizes: 8mm, 9mm, 10mm, 11mm, 12mm

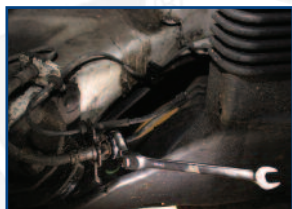

8553-BGS
FUEL FILTER REMOVAL KIT
OPEL/VAUXHALL

- ▶ Two part tool set for removing the fuel filter from the housing
- ▶ Prevents damage to expensive housing.
- ▶ Suitable for Vauxhall/Opel Vectra 1.9 JTD, Zafira 1.9DTH and some Fiat, Alfa Romeo and Saab 1.9d models.
- ▶ The plastic holder fits into a standard vice and the metal key grips and removes the filter from the housing



1738-BGS
VALVE LAPPING TOOL

- ▶ Facilitates the insertion of valves
- ▶ This simple attachment fits in to a standard drill chuck
- ▶ Quickly and effectively grinds valves in seconds
- ▶ Automatic change in direction
- ▶ For use with fine grinding paste
- ▶ With 8 mm shank

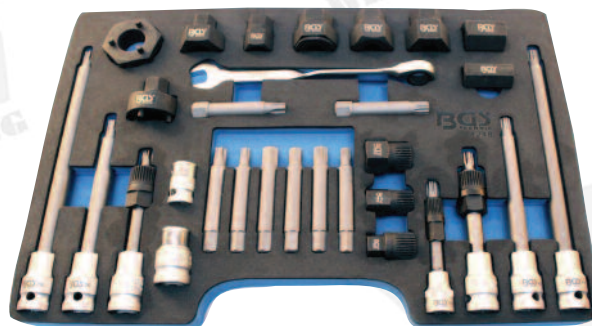

4248-BGS
30-PIECE ALTERNATOR TOOL SET

- ▶ Special alternator tool set including Splines & Torx bit sockets for the removal of Bosch, Marelli & Valeo alternator free-wheel drive pulleys
- ▶ Set includes bits for Locking the alternator, allowing the central locking bolt of the pulley to be released
- ▶ Includes both standard length and short length versions
- ▶ BMW / Ford / Mercedes / Renault / VAG - with Bosch, Marelli & Valeo type alternators



745100-MW
UNI-EXTENDER

- ▶ Specially designed to allow greater force to be applied with the use of conventional tools
- ▶ Forged lever extension for loosening stubborn bolts
- ▶ Ideal for hard to reach places
- ▶ Suitable for open-end wrench, combination wrench, offset ring spanner



1015-WW
OIL PLUG REPAIR KIT

- ▶ Allows the repair of broken oil sumps
- ▶ Sizes M15, M18, M20



1088-WW
SPECIAL DIESEL GLOW PLUG
SOCKETS

- ▶ Suitable for the removal of glow plugs in most popular diesel engines
- ▶ Internal rubber retaining ring holds glow plug secure when inserting or removing
- ▶ 8 - 19 MM



865-BGS
PROFESSIONAL DENT REMOVAL KIT

- ▶ Suitable for repair of minor dents
- ▶ Painting and filling work are unnecessary
- ▶ No colour differences
- ▶ Reduces time and cost
- ▶ Includes: 9 dent pads in various sizes and shapes, special adhesive glue sticks with very good performance for best results, sliding hammer to pull out hard dents, pulling unit with rubberized feet for slight dents on flat surfaces, plastic scraper for gentle removal of dent pads



867-BGS
REPLACEMENT
GLUE STICKS



866-BGS
REPLACEMENT
DENT PADS

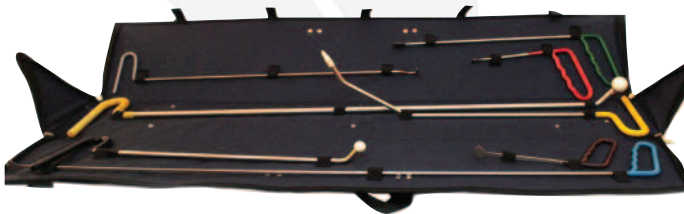

1040-WW
ELECTRIC HOT STAPLER

- ▶ Hot stapler plastic repair system complete with 300 assorted staples
- ▶ Electronic temperature control works on all Thermo plastics
- ▶ Supplied with 300 assorted stainless steel staples Reduces epoxy wastage
- ▶ Spare staples available separately
- ▶ For use on plastic lugs, plastic bumpers, motorcycle fairings etc.
- ▶ Quick effective repair method

1659-WW
PAINTLESS DENT REPAIR KIT

- ▶ For the removal of dents in a car's body without damaging the finish
- ▶ Ideal for removing small dents and damaging caused by hail
- ▶ Various head types: 2 half-round bars 21 & 22 cm, 1 round bar 42 cm, 1 half-round pointed bar 60 cm, 2 angled ball-headed bars 46 & 100 cm, 1 pointed bar 56 cm, 1 special-type hooked bar 107 cm
- ▶ Delivered in a handy carrying case



1040-1
1040-2
1040-3
SPARE STAPLES



1659-BALL
SPARE PADS



1038-WW
AIR SUCTIONED PROFESSIONAL
DENT PULLER

- ▶ Dent puller with 3 suction pads
- ▶ Allows for the easy removal of dents on all panels
- ▶ Hand operated Suction allows for extreme suction





- 8540-BGS**
AIR NEEDLE SCALER
- ▶ Ideal for removing rust and paint
 - ▶ Stroke speed: 4000 bpm
 - ▶ Air pressure: 90 psi (6.2 bar)
 - ▶ Air consumption: 7.0 cfm (198 l/min)
 - ▶ Air inlet: 1/4"
 - ▶ Weight: 4.19 lbs (1.90kgs)
 - ▶ Length: 13" (330 mm)



- 3515-BGS**
AIR HAMMER
- ▶ Suitable for work on car body and for mechanics
 - ▶ Includes: 4 chisel with different profiles, quick release head

3281-BGS
1/2" IMPACT WRENCH 822NM

- ▶ Torque: 822 Nm
- ▶ RPM: 7200 rpm
- ▶ Max. working pressure: 6.2 bar
- ▶ Air connection: 1/4"
- ▶ Aluminium hosing
- ▶ Right and left direction
- ▶ Power is adjustable by step switch
- ▶ Weight: 2900g
- ▶ Air consumption: 5 cfm
- ▶ Length: approx. 170 mm



3234-BGS
1/4DR STUBBY AIR RATCHET

3239-BGS
3/8DR STUBBY AIR RATCHET

- ▶ Max. torque 34 NM
- ▶ Free speed: 240 rpm
- ▶ Length 175 mm
- ▶ Max. 6.2 bar

1007-WW
HEAVY DUTY IMPACT WRENCH 1355NM

- ▶ Weight 2200 g
- ▶ Torque 1355 NM



3290-BGS
AIR ECCENTRIC SANDER / POLISHER

- ▶ 150 mm velcro holder for polishing and grinding discs
- ▶ Rotation speed: 10,000 rpm
- ▶ Max. working pressure: 6.2 bar
- ▶ Length: 225 mm
- ▶ Weight: 1900g



3235-BGS
3/4DR HEAVY DUTY IMPACT WRENCH 1355NM

- ▶ Weight 2200g
- ▶ Torque 1355 NM



1031-WW
MINI POWER HOUSE AIR IMPACT GUN 680NM

- ▶ Extra small and light weight edition
- ▶ Torque 680 NM
- ▶ Free speed 11.00 RPM
- ▶ Sound pressure 87 DBA



3240-BGS
1"DR IMPACT WRENCH ANVIL VERSION 2170NM



8538-BGS
AIR BLOW GUN WITH VENTURI NOZZLE

- ▶ The Venturi nozzle increases the air flow rate many times
- ▶ Making it easier to loosen dust

3260-BGS
PNEUMATIC BODY SAW

- ▶ Free speed: 9.000 rpm/min
- ▶ Length: 235 mm
- ▶ Weight: 770 g
- ▶ Air consumption: 120 L/minute
- ▶ Air pressure: 6,3 bar
- ▶ Noise level: 72,0 dB (a)
- ▶ Acceleration: 26,0 m/s²
- ▶ Max. cutting capacity: 1,2 mm



3264-BGS
AIR DIE GRINDER

- ▶ Heavy and robust extended air die grinder for
- ▶ Universal use
- ▶ For contour grinding, cutting, polishing, shaping, deflashing and keying



1159-BGS
MAGNETIC AIR TOOL HOLDER

- ▶ Holds air impact wrenches, wheel nut sockets and torque wrenches on lifting platforms
- ▶ 2 strong magnets
- ▶ 23 kg lifting capacity



1111-WW (1/4DR)
1112-WW (3/8DR)
MINI PALM AIR RATCHETS



1054-WW
AIR BRAKE WIND BACK SPINDLE

- ▶ Air operated brake spindle
- ▶ Left & right action
- ▶ Universal use

3274-BGS
AIR SANDER

- ▶ For the proper removal of stickers, adhesive residue and films on smooth surfaces and coatings
- ▶ Specially designed for use on vehicles
- ▶ Also for use on aluminium, metals, glass and plastic
- ▶ After working surfaces are polished
- ▶ Especially suitable for professional vehicle preparation
- ▶ With 28 and 34 mm Hoover connection
- ▶ Includes adaptors for: 110 mm abrasive cleaning fleece, 110 mm erasers and adaptation for round steel brushes
- ▶ All disks available separately



3271-BGS
EXTRA LONG AIR DIE GRINDER



3269-BGS
AIR ANGLED DIE GRINDER



9905-BGS
530NM BATTERY IMPACT WRENCH



3291-BGS
AIR ANGLE SANDER

15501-BGS

149-PIECE PROFESSIONAL TOOL KIT

- ▶ 1/4" + 1/2" ratchets
- ▶ Sockets 1/4", Super Lock: 4-4,5-5-5,5-6-7-8-9-10-11-12-13-14 mm
- ▶ Sockets 1/2", Super Lock: 10-13-14-16-17-18-19-20-22-24-27-30-32 mm
- ▶ Spinner handle 1/4"
- ▶ Universal joint 1/4" + 1/2"
- ▶ Extension bar 1/4", 50 + 100 mm
- ▶ Extension bar 1/2", 125 + 250 mm
- ▶ Sliding T-part 3/8" inside to 1/2" outside
- ▶ 1/4" Adapter with retaining ball for 1/4" Bits
- ▶ Machinists hammer 300 g, HICKORY handle, DIN 1041
- ▶ Measuring tape 5 m, 19 mm, EEC
- ▶ Hex key wrench, satin finished, in foldable holder, 1,5 - 2 - 2,5 - 3 - 4 - 5 - 6 - 8 - 10 mm
- ▶ T-Star-wrench, satin finished, in foldable holder, T10 - T15 - T20 - T25 - T27 - T30 - T40 - T45 - T50
- ▶ Screwdriver PH 1 x 75 mm
- ▶ Screwdriver PH 2 x 100 mm
- ▶ Screwdriver slotted 5,0 x 0,8 x 75 mm
- ▶ Screwdriver slotted 6,5 x 1,2 x 100 mm
- ▶ 200 mm magnetic holder for bits 1/4"
- ▶ 1/4" bits assortments, colour coded
- ▶ PZ 1 - 2 - 3 and PH 1 - 2 - 3
- ▶ Slotted 3 - 4 - 5 - 6 mm
- ▶ T-Star T10 - T15 - T20 - T25 - T27 - T30 - T40

- ▶ Hex 3 - 4 - 5 - 6 mm
- ▶ bit holder with 1/4" drive for 1/4" bits
- ▶ quick release bit holder
- ▶ Retractable knife 18 mm
- ▶ 140 mm voltage tester, with holding clip, 125 - 250V
- ▶ 300 mm water level, 3 vials, aluminium
- ▶ 250 mm tower pincer
- ▶ 250 mm water pump pliers, 2-component handles
- ▶ 180 mm universal scissor, 2-component handles
- ▶ 180 mm combination pliers, 2-component handles
- ▶ 160 mm long nose pliers, 2-component handles
- ▶ 160 mm diagonal cutting pliers
- ▶ 235 mm crimping pliers
- ▶ Terminals assortment, 30-piece
- ▶ CR-V combination wrenches, chrome plated, heads polished 8 - 10 - 11 - 12 - 13 - 15 - 17 - 19 mm
- ▶ adjustable wrench 8"
- ▶ Circlip pliers (internal) 165 mm
- ▶ Circlip pliers (external) 165 mm
- ▶ 260 mm hack saw, for 150 mm blades
- ▶ 150 mm saw blades, 3-piece



4100-BGS

8 DRAW ROLLER CABINET



67150-BGS

3-PIECE MAGNETIC TOOL HOLDERS

- ▶ 3 shelves with strong magnet
- ▶ Individually attachable
- ▶ Sticks to all metal surfaces
- ▶ Perfect storage box for tools, aerosol cans and other tools
- ▶ Sizes: 150 x 120 mm, max. load capacity 0.60 kg
210 x 120 mm, max. load capacity 0.77 kg
310 x 120 mm, max. load capacity 1.17 kg

4085-WW

ROLLER CABINET WITH 245PC TOOL SELECTION

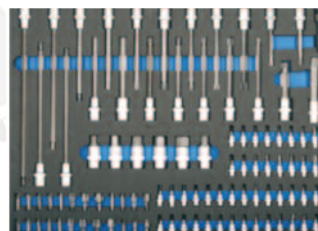
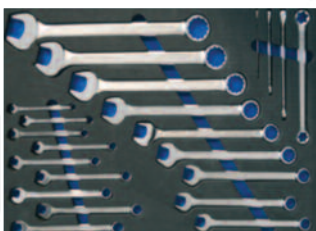
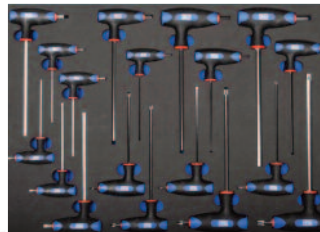



1207-BGS
21-PIECE 3/4" SOCKET SET

- ▶ Pro-Torque® sockets
- ▶ 16 hexagon sockets
 19-21-22-23-24-26-27-30-32-34-36-38-41-46-48-50 mm,
- ▶ 1 reversible ratchet 500 mm with quick release button, black finish head
- ▶ 3 extension bars 100 - 200 - 400 mm
- ▶ 1 sliding tee bar 450 mm



5258-BGS
21-PIECE IMPACT 3/4" SOCKET SET

- ▶ Pro-Torque® sockets
- ▶ 16 hexagon sockets
 19-21-22-23-24-26-27-30-32-34-36-38-41-46-48-50 mm
- ▶ All parts can be used with 3/4" impact wrench, it is not necessary to buy additional air impact sockets



5246-BGS
TRUCK / LGV TORX, SPLINE XL SOCKET KIT

- ▶ T-Star T60-70-80-90-100
- ▶ Int. Hex. 17-19-22-24 mm
- ▶ E-Type E18-20-22-24
- ▶ 2 bit holder for 3/4" and 1" drive
- ▶ Key wrench for adjusting bits in the holder
- ▶ For use with air tools



1210-BGS
154-PIECE 1" SOCKET SET 36 MM – 85 MM

- ▶ 24 tooth reversible ratchet
- ▶ 2 extension bars 200mm & 400 mm
- ▶ With 500mm long sliding tee bar incl. adaptor for unscrewing of very tough nuts
- ▶ Length of the ratchet approx. 680 mm
- ▶ 10 hex. sockets 36-41-46-50-55-60-65-70 -75-80 mm
- ▶ Especially for use in farming and heavy duty applications



5052-BGS
12-PIECE ALLAN KEY BIT SOCKETS

- ▶ Sizes 5,6,7,8,10,12,14,16,17,18,19,22



5100-BGS
19-PIECE MALE / FEMALE TORX SET

- ▶ TORXS; 20-25-27-30-40-45-50-55-60-70
- ▶ FEMALE: 10-11-12-14-16-18-20-22-24



5021-BGS
34-PIECE TORX SET

- ▶ 11 bit-sockets T10-T60 not tamperproof
- ▶ 10 bits T10-T55 tamperproof
- ▶ 1 bit-holder
- ▶ 12 Female-Type sockets E 4-E 20
- ▶ All sockets spiral-knurlled and with ball bearing for secure socket holding



1900-BGS (METRIC)
110-PIECE METRIC TAP & DIE SET

- ▶ Especially for fine threads
- ▶ Tungsten steel
- ▶ 2 tap holders
- ▶ 2 die holders
- ▶ 1 T holder
- ▶ Each 35 taps (pre- AND and cutter for each size) and dies in following sizes / flank leads: M2 x 0.4 - M3 x 0.5 - M4 x 0.7
 M5 x 0.8 - M6 x 1.0 - M6 x 0.75 - M7 x 1.0 - M7 x 0.75 - M8 x 0.75
 M8 x 1.0 - M8 x 1.25 - M9 x 0.75 - M9 x 1.0 - M9 x 1.25 - M10 x 0.75
 M10 x 1.0 - M10 x 1.25 - M10 x 1.5 - M11 x 0.75 - M11 x 1.0
 M11 x 1.25 - M11 x 1.5 - M12 x 0.75 - M12 x 1.0 - M12 x 1.25
 M12 x 1.5 - M12 x 1.75 - M14 x 1.0 - M14 x 1.25 - M14 x 1.5
 M14 x 2.0 - M16 x 1.0 - M16 x 1.5 - M16 x 2.0 - M18 x 1.5

- 900-BGS (IMPERIAL)**
- | | | | |
|-----------|-----------|------------|------------|
| 4-40UNC | 6-32UNC | 8-32UNC | 10-24UNC |
| 10-32UNF | 12-24UNC | 1/4-20UNC | 1/4-28UNF |
| 1/4-24UNS | 1/4-32UNS | 5/16-18UNC | 5/16-24UNF |
| 3/8-16UNC | 3/8-24UNF | 7/16-14UNC | 7/16-20UNF |
| 1/2-13UNC | 1/2-20UNF | 9/16-12UNC | 9/16-18UNF |
| 5/8-11UNC | 5/8-18UNF | 3/4-10UNC | 3/4-16UNF |
| M6X1,0 | M8X1,25 | M10X1,5 | M10X1,0 |
| M11X1,5 | M12X1,25 | M12X1,75 | M14X1,25 |
| M18X1,5 | 1/8-27NP | 1/4-18NPT | |



1950-BGS (METRIC)
130-PIECE HSS THREAD REPAIR SET

- ▶ 5 HSS-G-taps
- ▶ 5 HSS-G-twist drills
- ▶ 5 special installation tools
- ▶ 5 tang breakers
- ▶ 110 thread inserts:
- ▶ Each 25 pieces: M5x0.80, M6x1.00, M8x1.25, M10x1.50
 10 pieces: M12x1.75

1951-BGS (METRIC)

- ▶ 5 HSS-G-taps
- ▶ 5 HSS-G-twist drills
- ▶ 5 special installation tools
- ▶ 5 tang breakers
- ▶ 110 thread inserts: each 25 pieces: M6x1.00, M8x1.25, M14x1.2
 20 pieces: M10x1.5 15 pieces: M12x1.75



1632-BGS
10-PIECE SPOT WELD DRILL SET

- ▶ Spot weld cutter with double ended-crown
- ▶ 9.5 mm Cobalt-HSS-spot
- ▶ Weld drill 8x80 mm
- ▶ 5 double ended cutter crowns 9.5 mm
- ▶ 2 pilot pins



1930-BGS
DIGITAL VERNIER CALIPER

- ▶ Extra large display
- ▶ Scale in mm/inch, reading 1/100 mm
- ▶ Zero reset in any position, metric/inch conversion
- ▶ +/- display
- ▶ Incl. battery



1600-BGS
WELDING SPOT CUTTER 70MM LONG

- ▶ Tip manufactured from HSS
- ▶ A quality tool in constructing bodies for separating spot welded sheet metals



148-BGS
BRAKE THREAD REPAIR SET

- ▶ 10 thread replacers (available separately under item# 148-1)
- ▶ 1 step drill
- ▶ 3 drill guide plate (for VAG, Opel, Ford)
- ▶ 1 hand tap
- ▶ 1 hexagon wrench



7729-BGS
10 TON HYDRAULIC PULLER SET

- ▶ Hydraulic ram
- ▶ Each 3 legs in following lengths: 100, 150 and 200 mm
- ▶ One twin head and one triple head
- ▶ 2 extension rods
- ▶ Separator from 20-105 mm



7760-BGS
12-PIECE MANUAL PULLER SET

- ▶ Pulling depth up to approx. 105 - 210 - 265 mm, pulling width up to max. 135 mm
- ▶ Puller legs are suitable for 2- and 3-leg crossbars (included)
- ▶ Free moving legs allow internal and external pulling operations
- ▶ Hardened pulling feet (width approx. 25 mm, thickness approx. 2 mm)
- ▶ 2 spindles 165 + 280 mm with fine thread



7735-BGS
WHEEL BEARING SLIDE HAMMER 4KG

- ▶ For flanges with 4 and 5 hole
- ▶ Hole distance of 100 to 115 mm
- ▶ Thread size up to M14
- ▶ 4kg sliding hammer
- ▶ Length 570 mm



1016-WW
UNIVERSAL PULLEY PULLER

- ▶ Universal Puller to pull pulleys
- ▶ Use on Injection Pumps, Camshafts, Timing Belts etc

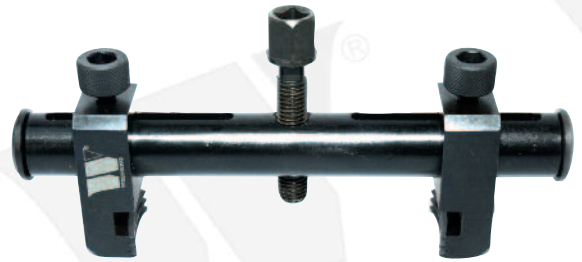

1013-WW
RIBBED DRIVE BELT PULLEY

- ▶ Allows for a easy removal with out causing unnecessary damage to the pulley
- ▶ Ideal for Crankshafts, Alternators, Air conditioning Systems, Water Pumps

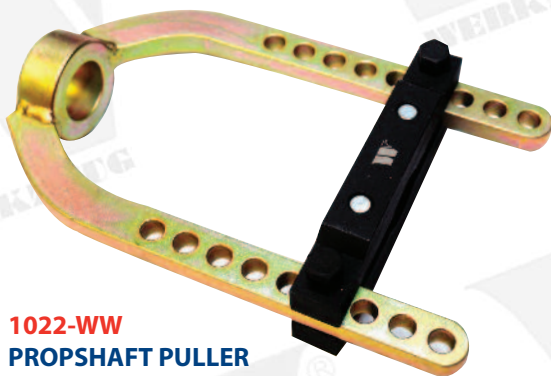

1022-WW
PROPSHAFT PULLER

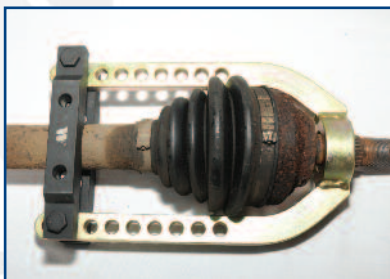

798-BGS
P-PIECE NEEDLE & HOOK SET

- | | |
|----------------------|-------------------------------------|
| ▶ Mini straight pick | ▶ Large straight pick |
| ▶ Mini full hook | ▶ Large full hook |
| ▶ Mini 45° hook | ▶ Large 45° hook |
| ▶ Mini 90° hook | ▶ Large 90° hook |
| ▶ Large 1" scraper | ▶ With ergonomic slip-guard handles |



1876-BGS
DEAD BLOW HAMMER

- ▶ Plastic handle
- ▶ Blow-back proof due to steel balls in the head of the mallet, therefore stronger impact
- ▶ Especially for loosening stuck rims when changing tires
- ▶ Extra heavy duty for trucks and SUV
- ▶ Weight 4500g

8494-BGS
5-PIECE FILE SET

- ▶ Consisting of: Flat file, 250 mm, H1 (coarse), Flat file, 200 mm, H2 (medium fine), Half-round file, 200 mm, H1 (coarse), Triangular file, 150 mm, H2 (medium fine), Round file, 150 mm, H1 (coarse)
- ▶ With plastic handle



8491-BGS
LED PEN LIGHT



8455-BGS
LED WORKING LAMP



1140-BGS
OXYGEN SENSOR SOCKETS

- ▶ For assembly of oxygen sensors, radiator thermo switch and Diesel injection nozzles



1757-BGS
22-32 MM CROWFOOT WRENCHES

- ▶ Sizes: 20-21-22-23-24-25-26-27-28-30-32 mm
- ▶ 1 extension bar 125 mm
- ▶ 1 flexible handle 385 mm



1003-BGS(60-105MM)
1011-BGS (60-160MM)
HEAVY DUTY OIL FILTER WRENCH CHAIN

- ▶ Heavy duty tool with duplex chain
- ▶ Chain width approx. 22 mm
- ▶ Handle satin chrome plated
- ▶ Claw prevents slipping
- ▶ 180° swivel handle
- ▶ Ease to use due to special chain-lock
- ▶ Suitable for oil filters



1014-BGS
OIL SUMP SOCKETS

- ▶ Gearbox, Axle Drain Key Set
- ▶ Suitable for a multiple of applications
- ▶ Universal use
- ▶ Gearbox, Axle Drain Key Set
- ▶ Suitable for a multiple of applications



1149-BGS
OXYGEN SENSOR & INJECTOR SOCKET SET



8552-BGS
CYLINDER HEAD REPAIR TRAY

- ▶ Needed when repairing cylinder heads, e.g. replacing the valves, hydraulic valve lifters, valve stem seals, etc.
- ▶ Allows a safe and confusion free storing of components, such as camshafts, valves, valve springs, hydraulic tappets, shims, etc.
- ▶ Dimension: 400 x 450 x 260 mm



1721-BGS

FUEL, AIRCO, OIL LOCKING PLIERS

- ▶ For locking hoses during repair jobs
- ▶ Prevents spillage and leakage of operation liquids
- ▶ For e.g. brake hoses, air conditioning hoses, power steering hoses
- ▶ Contains 8 line stoppers

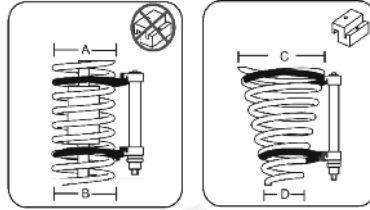

1006-WW

HEAVY DUTY COIL SPRING COMPRESSOR

- ▶ Maximum capacity approx. 1050kg / 10200 Nm
- ▶ Maximum opening width 300mm
- ▶ With 3 sets of Jaws: 60-125mm, 88-160mm, 126-212mm
- ▶ Chrome molybdenum steel
- ▶ Plastic coated jaws protect the springs from a loss of the antirust coating



1114-WW

UNIVERSAL COIL SPRING COMPRESSOR FOR WISH BONE / MULTILINK SUSPENSION

- ▶ Universal spring compressor for wishbone/multilink suspension with angled jaws
- ▶ Makes it easier, safer and more convenient to position the tool correctly inside the spring
- ▶ Prevents overload
- ▶ Improves safety
- ▶ Handles 95% of all cars with wishbone/multilink suspension rear example VW Touran, Citroën C3, Skoda Octavia, Peugeot 107



8385-BGS

ELECTRONIC BRAKE RESETTING TOOL

- ▶ EPB / SBC trouble code reading and clearing
- ▶ SBC / EPB system activation and deactivation
- ▶ inspection of brake systems
- ▶ position of rear brake piston must be set before and after changing brake discs & pads
- ▶ Suitable for: Audi A6/ AS (2004-2012), VW Passat (2005-2012), Mercedes E211/E219 Mercedes S221 Etc
- ▶ Display: backlight, 128 x 64 pixel display
- ▶ Operating temperature: 0-60° C
- ▶ 9V cell battery
- ▶ Dimensions: 209x107x37 mm
- ▶ User's manual included



3532-BGS

ELECTRONIC STETHOSCOPE

- ▶ Facilitates finding the location of noise sources and reduces the diagnosis time
- ▶ Enables fast and uncomplicated acoustic testing for alternators and other parts of the engine
- ▶ Headset features a padded headband and ear cups for excellent wearing comfort



1650-BGS

28-PIECE HEAVY DUTY PUNCH & CHISEL SET



65520-BGS

ABS SENSOR CLEANERS

- ▶ It is necessary to use the reamers before renewing the ABS sensors
- ▶ Suitable for Mercedes, Ford, Daewoo, Audi, BMW, Peugeot, Renault, VW and other cars
- ▶ Reamer Ø18 mm x length 23 mm and Ø15 mm x length 23 mm
- ▶ 1/4" T-handle
- ▶ Reamers can also be used with 1/4" ratchet



8395-BGS

UNIVERSAL FILTER WRENCH

- ▶ For filter diameter from 60 to 80 mm
- ▶ Universal use for many filters
- ▶ Self-locking by spring mechanics



320-700-MW
20 TON HYDRAULIC KIT

- ▶ Perfect combination tool for Press + Pull sleeve set 1027-WW
- ▶ Allows for 20 Ton pressure in pushing and pulling
- ▶ Usable on 1033-WW, 67305-BGS,

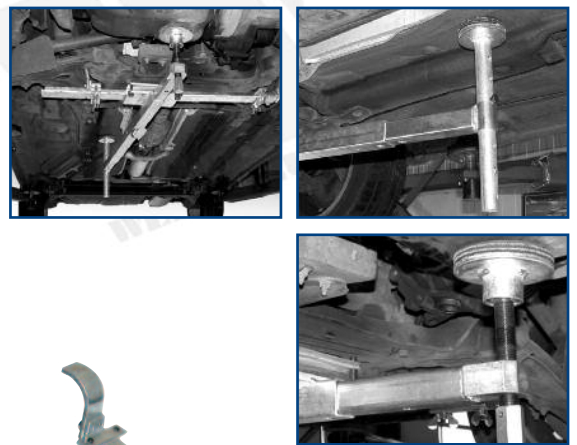

510013-MW
UNIVERSAL ENGINE SUPPORT

- ▶ Universal engine support device for safe disassembly of the motor suspension (engine support)
- ▶ The support is attached directly to the vehicle cross member



431020-MW
MOUNTING UNIT FOR SHOCK ABSORBER

- ▶ For the easy and safety mounting of suspensions with inner-spring
- ▶ Can be used for e.g. BMW, Mercedes, Toyota, Peugeot, Fiat, Ford etc
- ▶ Fits for different suspensions, e.g. SACHS etc



WE SET THE STANDARD FOR TORQUE!

1114-MW
CORDLESS IMPACT GUN 1000 NM

- ▶ ULTIMATE POWER
- ▶ One handed Forward/Reverse switch
- ▶ Ergonomic handle
- ▶ 18v 3.0Ah Lion Battery
- ▶ 50 Min Recharge
- ▶ Weight only 3.0Kg
- ▶ Breakaway Torque 100Nm

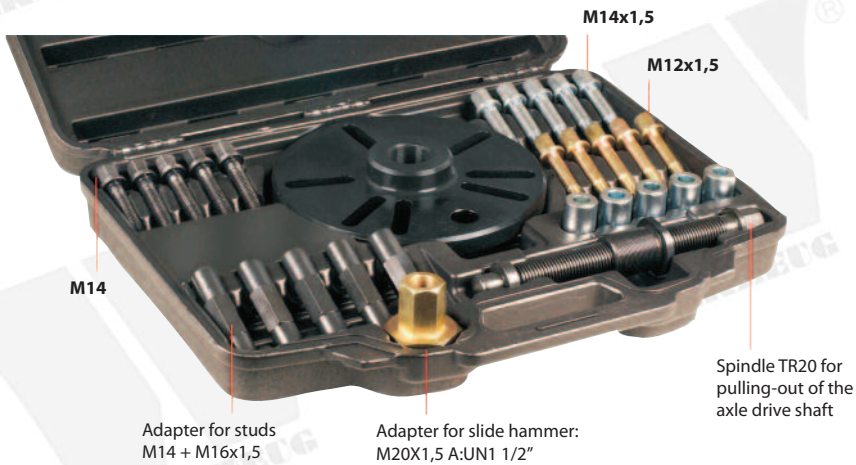

Option: 12 to. Hydraulic spinal

Spindle TR20 for pulling-out of the axle drive shaft

43344-MW WHEEL HUB PULLER SET FOR COMMERCIALS

Ford Transit, Sprinter, Renault Master, Fiat Ducato, Boxer

- ▶ For the demounting of Brake drums, Brake Disc, Wheel Hubs, Bearing-Hub Unit, Driveshaft's Etc.
- ▶ Vibro spindle compatible with Air impact wrench
- ▶ Can also be used with Hydraulic Spindle + Slide Hammer 7772

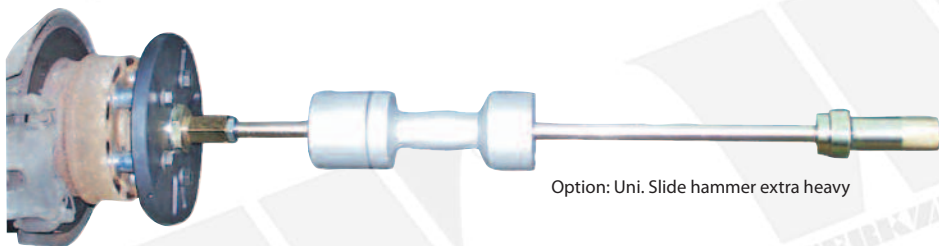

Option: Uni. Slide hammer extra heavy



1600NM

1.8kg

294114-MW THE POWER HOUSE IMPACT WRENCH 1600NM

- ▶ Ergonomically matched grip
- ▶ Lever switch can be switched to either hand
- ▶ Speed forward and reverse switch can be operated with one hand



432800-MW LOCKING WHEEL NUT REMOVAL SET

USABLE FOR ALMOST EVERY LOCKING WHEEL NUT

- ▶ No drilling, now chiselling, no damage of the aluminium wheel
- ▶ No destroying of the locking nut
- ▶ Superb time saving as only 30 seconds needed for one wheel nut



556000-MW MOTOR OIL FUNNEL

- ▶ Made for the clean and easy filling of engine oil
- ▶ Quick coupling for direct and sealed connection
- ▶ Fits universal for all VAG GROUP



1050-WW
9PC SPECIAL WHEEL LOCK REMOVAL SET

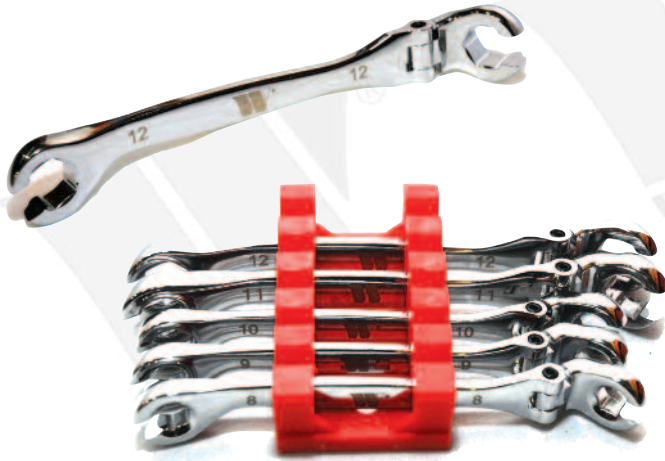

1004-WW
LINE SPANNERS WITH FLEXI JOINT

- ▶ Especially designed for brake lines, fuel lines, oil lines etc
- ▶ 270 Degree swivel
- ▶ Sizes 8mm 9mm 10mm 11mm 12mm



1046-1-WW
5-PC HEAVY DUTY PRY BAR SET

- ▶ Heavy-duty pry bars made of tempered square steel that you can hit without causing damage to the handle
- ▶ Brand New non slip handles
- ▶ Increased tip width for maximum contact
- ▶ Sizes Include 20cm , 30cm, 45cm, 60cm, 100cm

8593-WW (EXCLUSIVE)
TURBOCHARGER PRESSURE TESTING SYSTEM

- ▶ Includes all conventional hose diameter seal plugs for the pressure testing of turbochargers
- ▶ The system is sealed by the plugs and pressurised
- ▶ Safety valve protecting the system from excessive pressure
- ▶ Allows the quick and easy location of leaks
- ▶ Professional + Low cost fault detection
- ▶ Universal for almost all Vehicles
- ▶ Size 1 length 60 mm x 35 / 40 / 45
- ▶ Size 1 length 60 mm x 50 / 55 / 60
- ▶ Size 1 length 60 mm x 65 / 70 / 75
- ▶ Size 1 length 60 mm x 80 / 85 / 90



1121-WW (12/24V 3200A)

1122-WW (12V 2000A)

EXTREME POWER STARTER

- ▶ Superior quality components guarantee reliability and high levels of safety
- ▶ Starts up to 30 cars before recharging is needed*
- ▶ LED Power level indicator
- ▶ Impact resistant, durable and robust casing
- ▶ Automatic Charger with smart circuit which allows the unit to be left in continuous charge without incurring damage

12V

24V





1070-WW
VIBRATION HAMMER & KIT

- ▶ A unique concept to aid the removal of seized suspension parts and ball joints, steering racks etc
- ▶ The system allows for the controlled application of force providing 2100 equivalent hammer blows every 37 seconds via an specially designed welzh air powered Impact Hammer allowing the operator to control and gradually increase the force being applied, in order to loosen the seized components
- ▶ Whilst the Air Hammer has been designed for use on suspension parts there are a number of additional applications where its use may prove to be convenient e.g. :
 - ▶ Seized or rusted nuts / bolts on any part of the vehicle, the high frequency vibrations alleviate rusted conditions
 - ▶ Seized injectors where there is no need to retain the injector for future use using it to loosen carbon deposits around the injector prior to using a puller either manual or hydraulic
 - ▶ Locking wheel nut adaptor also included in the kit



STEERING RACK



INCLUDES ADAPTOR FOR USE WITH
 LOCKING WHEEL NUT SOCKETS

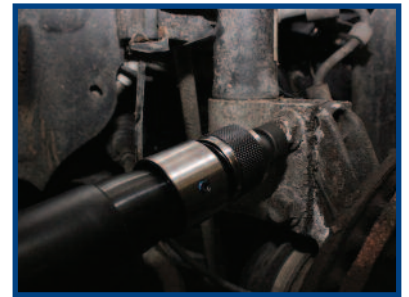

SEIZED OR RUSTED BOLT / NUTS



SEIZED BALL JOINT

YOUR DEALER:

All prices are suggested retail prices and are plus VAT
 Previous Prices cease with the publication of this Brochure.
 Welzh Werkzeug cannot except any liability for any possible errors,
 printing errors, product information inaccuracies and technical errors.
 All items in the brochure are subject to availability.
 Sold only through retailers.

© Copyright 2013 by Welzh Werkzeug Ltd

Welzh Werkzeug Ltd
 1-6 The Green | Eastriggs | Scotland | DG12 6NH
 Tel.: +44 (0)1461 700120 | Fax: +44 (0)1461 700181
 E-Mail: info@Welzhwerkzeug.com | www.welzhwerkzeug.com